

Core and coil lifting

Main body lifting

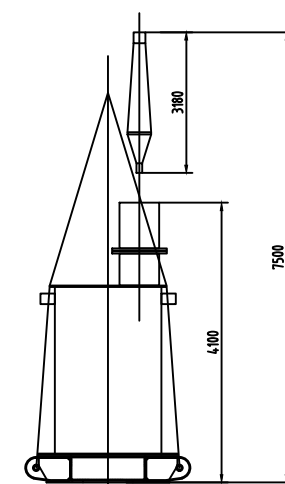

Unit:mm

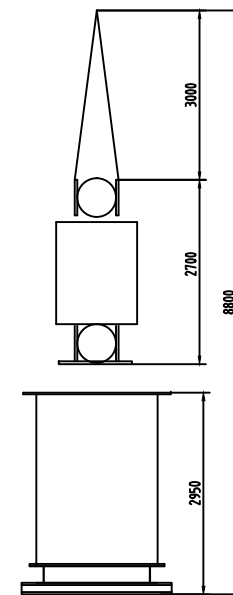
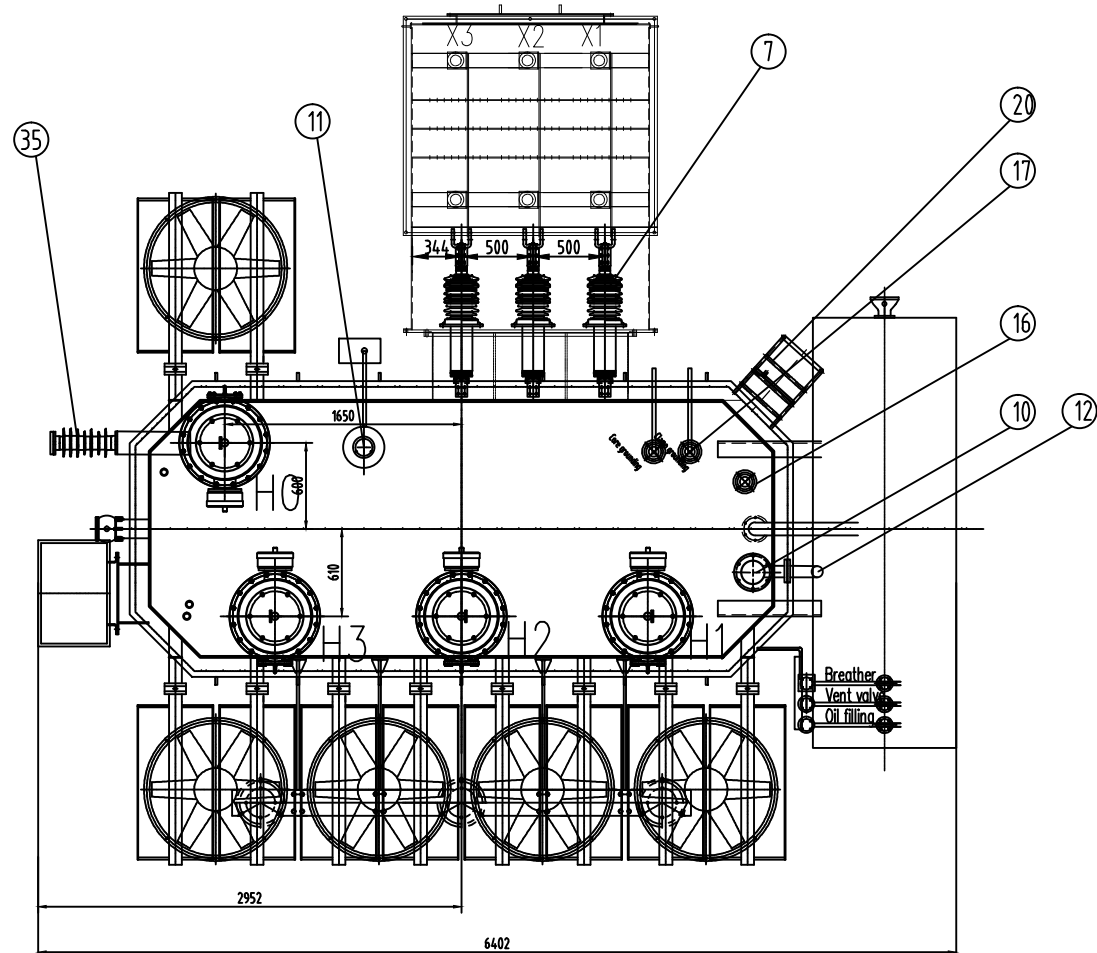

		Rev3	20141030	SF-75000/115	1ZDB300000P-1271		
Rev4		Design	xu dong wang 20140911	Outline drawing	Mark	Weight	Scale
Rev3	20141030	Check	zhi xiang zhu 20140911		Total: 3 Pages	Page 1	1:1
Rev2	20140922	Review	zhi xiang zhu 20140911	Mexico	CHNT Chint Electric Co., Ltd		
Rev1	20140918	Approve	zhao long zhang 20140911				

K view

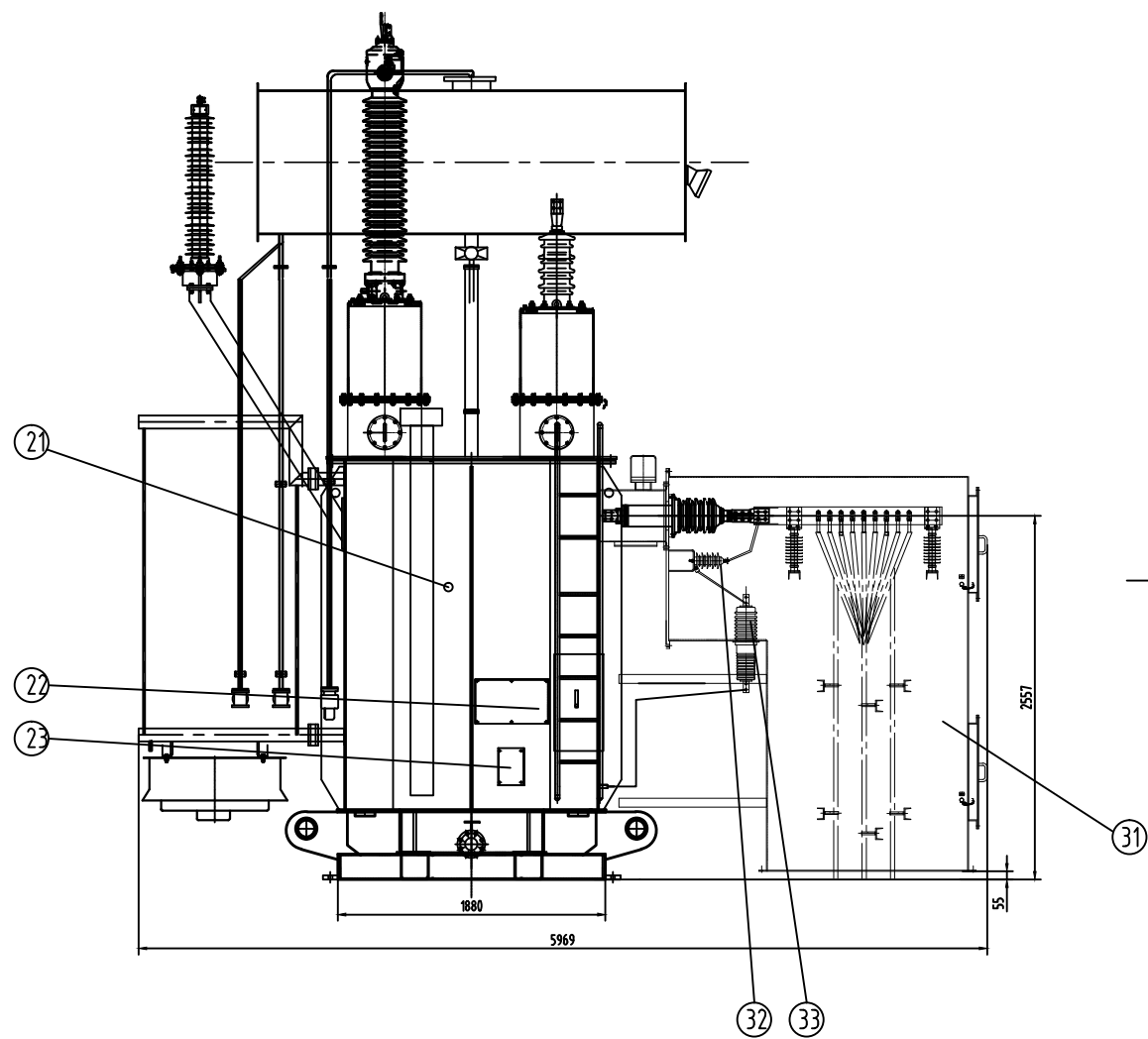

Bottom of tank

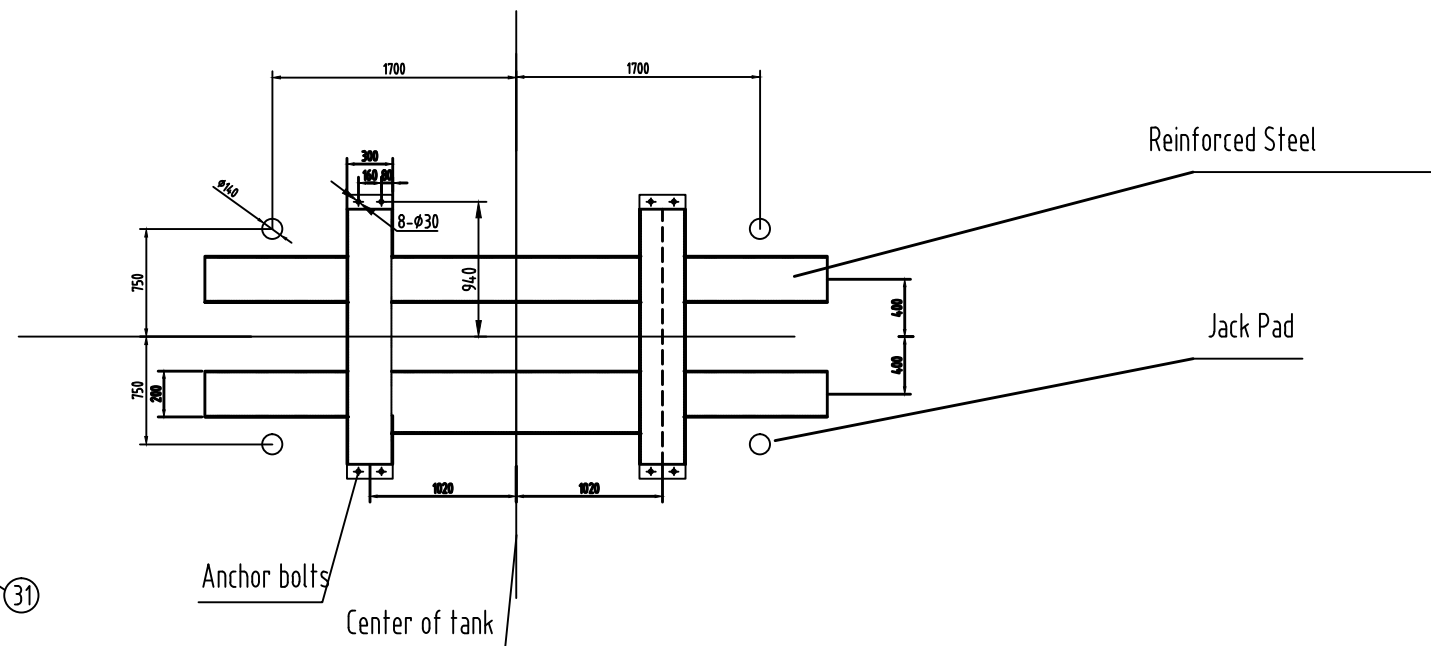

Unit:mm

		Rev3	20141030	SF-75000/115	1ZDB300000P-1271
Rev4		Design	xu dong wang 20140911	Outline drawing	Mark
Rev3	20141030	Check	zhi xiang zhu 20140911		Weight
Rev2	20140922	Review	zhi xiang zhu 20140911	Mexico	Scale
Rev1	20140918	Approve	zhao long zhong 20140911		Total: 3 Pages
					Page 2
					CHNT Chint Electric Co., Ltd

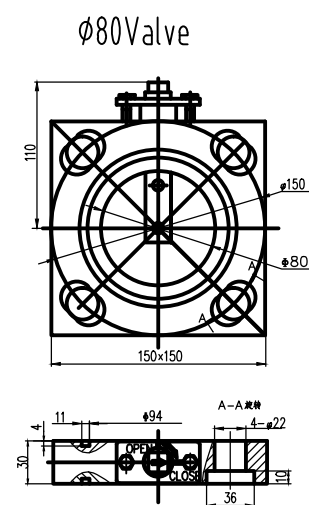

φ80 Valve

HV arrester terminal

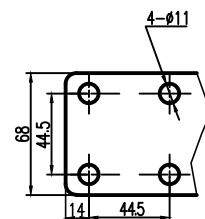

Arrester Bracket Drill Pattern

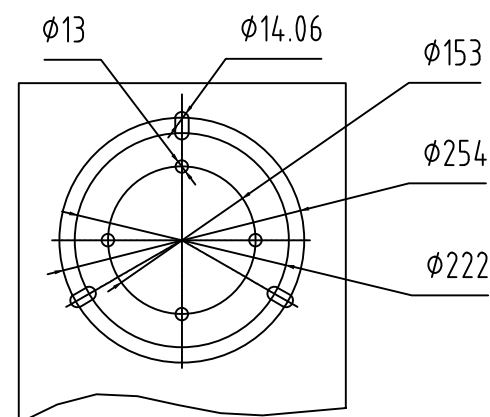

LV Bushing Terminal(COPPER)

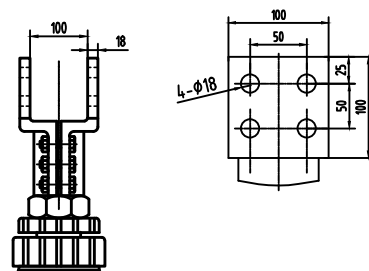

HV Bushing Terminal(COPPER)

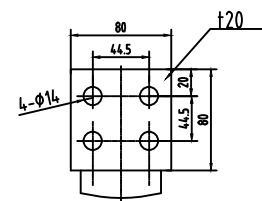

Tank Ground Pad

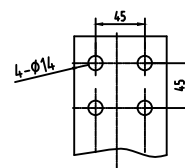

Weight list: (kg)

Active part weight	Total oil weight	transport weight Without Oil	Total weight
47800	16000	56600	80900

Unit:mm

35	FZSW-35/8.0	Support insulator	3				
34		HV arrester terminal	3				
33		Air to air bushing	1				
32	YH10W-15	LV arrester	3				
31		LV Chamber	1				
30	YH10W-90	HV arrester	3				
29		HV arrester Bracket	1	CHINT			
28		Terminal box	1	CHINT			
27	AKM3540112	Winding tempreature indication	1	Qualitrol			
26	AKM3440512	Oil tempreature indication	1	Qualitrol			
25	DN25	Gate valve	2	Hejian Yachen			
24	XS-1.5	Breather	1	Shenyang			
23	1ZDB107002D-	Oil level plate	1	CHINT			
22	1ZDB107001D-	Name plate	1	CHINT			
21	DN15	Oil sample valve	1	CHINT			
20		Ladder	1	CHINT			
19	φ140X20	Jack Pad	4	CHINT			
18	φ130X150	Lifting lug	4	CHINT			
17	BJLW-10/100	Grounding bushing	2	Shenyang Shenyang			
16	DN50	Gate valve	1	Hejian Yachen			
15	DBF-9Q12	Fan	5	he bei hua feng			
14	DN80	Butterfly valve	20	Zhuozhou Huafeng			
13	JPC1800/2200-28/520	Radiator	10	bao ding duo tian			
12		Deflector pipe	1	CHINT			
11	WSG	Off load tap changer	1	wu han tai pu			
10	55Kpa	pressure-relief valve	1	Qualitrol			
9	100X100	Tank ground pad	4	CHINT			
8	DN80	Gate valve	1	Hejian Yachen			
7	BYW-24/4000	LV Bushing	3	shen yang shen ya			
6	BJW-40.5/800-4	HV Neutral Bushing	1	shen yang shen ya			
5	BRDLW-126//630	HV Bushing	3	nan jing dian qi			
4	DN80	Butterfly valve	2	Zhuozhou Huafeng			
3	BC-80	Gas relay	1	EMB			
2	LLG042	Oil level indicating	1	Qualitrol			
1	φ1000x3000	Conservator	1	CHINT			

SN.	Code	name	No.	Material	Single parts weight	Total weight	remark
-----	------	------	-----	----------	---------------------	--------------	--------

Rev3	20141030	SF-75000/115	1ZDB300000P-1271
Rev4	Design	xu dong wang	20140911
Rev3	20141030	Check	zhi xiang zhu
Rev2	20140922	Review	zhi xiang zhu
Rev1	20140918	Approve	zhao long zhong

Outline drawing		Mark	Weight	Scale
Mexico		Total: 3 Pages		Page 3
		CHNT Chint Electric Co., Ltd		